

USAF A-12 & SR-71 CREW ACCESS STEPS ASSEMBLY INSTRUCTIONS

1:72 or 1:48 scale

© Aircraft In Miniature Limited - 2017

① FOLD THE PARTS

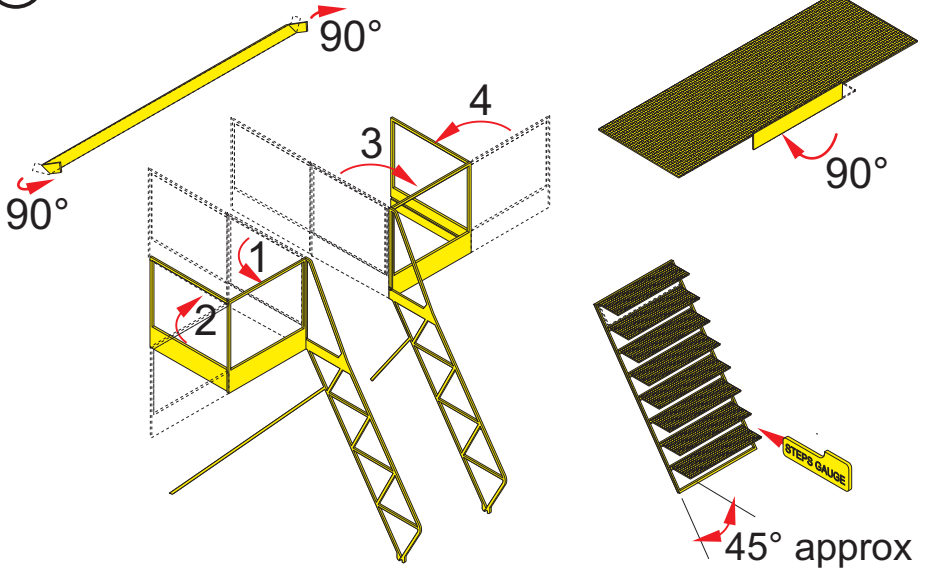

②

ASSEMBLE STEP SIDES AND PLATFORM

Assemble parts with cyanoacrylate (super glue) or epoxy cement.
Brass parts can be soldered.

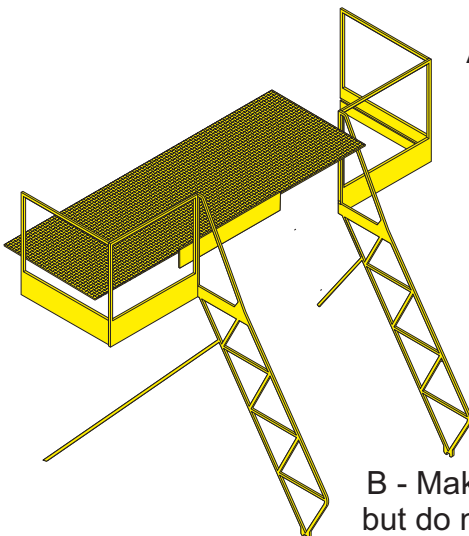

A - Attach stair sides to platform.

B - Make sure treads fit between sides,
but do not attach the treads at this time.

3 ATTACH THE STEPS TO THE BASE

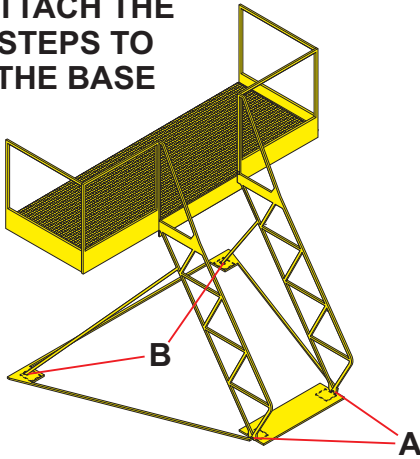

A - Put the stair sides on the base frame

B - Fold the side braces out until they fit in the sockets on the base frame. If necessary, trim the ends of the side braces until the platform is parallel to the base frame.

C - Attach the steps to the base frame.

4 FINAL ASSEMBLY

A - Put the aircraft bumper in position on the steps (do not attach it permanently at this time).

B - Put the steps against the model aircraft and adjust the angle of the bumper until it is flat against the fuselage, then attach the bumper to the steps.

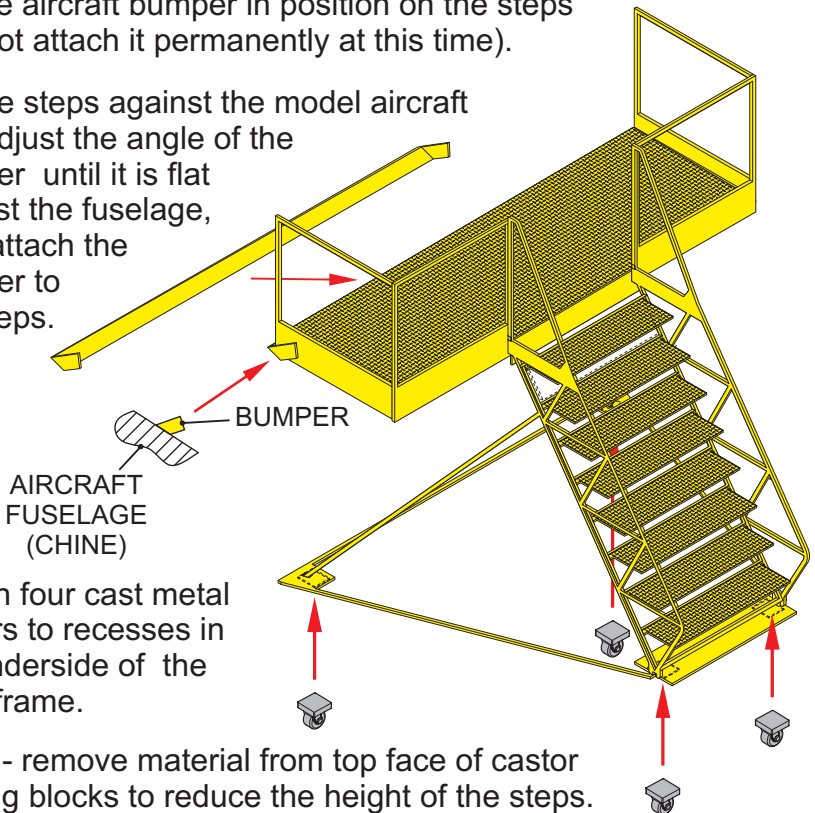

C - Attach four cast metal castors to recesses in the underside of the base frame.

NOTE - remove material from top face of castor mounting blocks to reduce the height of the steps.