



TRANSPORT WINGS

1:72 Mixed-media conversion pack



BOAC DC-7C Copyright unknown

Douglas DC-7C 'Seven Seas'

History, Notes and Instructions

*These instructions must be used in
conjunction with the Heller kit instructions*

History

The DC-7, first flown in May 1953, was basically a stretched longer-range development of the DC-6B with more powerful Wright Turbo Compound engines, four-blade propellers and additional fuel capacity. The DC-7 used the DC-6 wing with very minor changes. The improved DC-7B (1955) had the same dimensions as the DC-7 with a further increase in fuel capacity.

The ultimate DC-7 model, the DC-7C 'Seven Seas', which went into service in April 1956, was a DC-7 with extra fuel capacity and four Wright R3350EA1 or EA4 Turbo Compound engines. Its visual differences compared with the DC-7 and DC-7B were:

- a 40 inches fuselage stretch ahead of the wing
- a longer radar nose
- a taller and squarer tail fin
- 5 foot addition to the wing on each side of the fuselage, between the fuselage and the original DC-7 wings.

Some DC-7Cs were later converted into freighters (DC-7F) with two cargo doors and some of these were used for Rhodesian sanctions busting.

Description of this conversion pack

This conversion pack is for use with the Heller DC-6B kit and consists of resin parts for the fuselage plugs, wing centre section, engines, saddle tanks, and a replacement fin and rudder.

The conversion is in two parts, the fuselage and the wings, and is suitable for an experienced modeller.

Parts List

Resin parts

Engine - cowling	4 off
Engine - core	4 off
Engine - gills (closed)	4 off
Engine - gills (open)	4 off
Engine - exhaust section	4 off
Fin	1 off
Fuselage plug (left)	2 off
Fuselage plug (right)	2 off
Saddle tank - No.1	1 off
Saddle tank - No.2	1 off
Saddle tank - No.3	1 off
Saddle tank - No.4	1 off
Wing centre section	1 off

Metal parts

Propeller	4 off
---------------------	-------

Miscellaneous

Instructions	1 set
------------------------	-------

1 GENERAL

WARNINGS

- 1 THIS KIT CONTAINS SMALL AND/OR SHARP PARTS. KEEP THE CONTENTS OF THE KIT AWAY FROM CHILDREN.
- 2 USE ALL SOLVENTS, PAINTS, FILLERS AND OTHER MATERIAL IN ACCORDANCE WITH THE MANUFACTURER'S INSTRUCTION. OBEY ALL SAFETY WARNINGS.

2 PREPARE THE PARTS OF THE DC-6 KIT

A Cut the fuselage halves as shown in Figure 1.

- 1 Tape the fuselage halved together, then cut the fuselage in front of and behind the wing. The important things are that these cuts are in the parallel section of the fuselage and that the cuts in the two halves are aligned. Position the cuts to suit the window pattern of the aircraft being modelled.
- 2 Cut off and discard the fin and rudder from each fuselage half. Use the replacement fin and rudder as a guide for the position of the cuts.

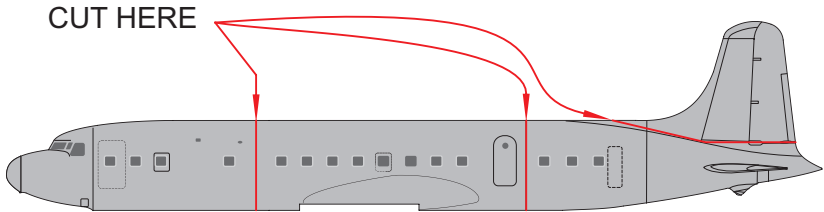
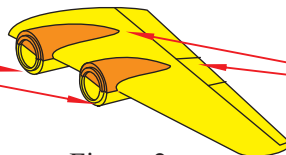

Figure 1

B Modify the wings as shown in Figure 2.

- 1 To prepare each lower wing, remove the engine alignment tabs from the front of each nacelle.
- 2 Remove the nacelles from each upper wing and put a plastic card filler in the space left where the nacelles are removed. When completed the upper wing surface should be a smooth aerofoil surface.
- 3 Assemble the wing as detailed in the kit instructions, then cut off the outer wings to suit the new centre section.

REMOVE ENGINE
ALIGNMENT TABS



REMOVE UPPER
NACELLES AND
FILL SPACE WITH
PLASTIC CARD

The left wing is shown.
The right wing is similar.

Figure 2

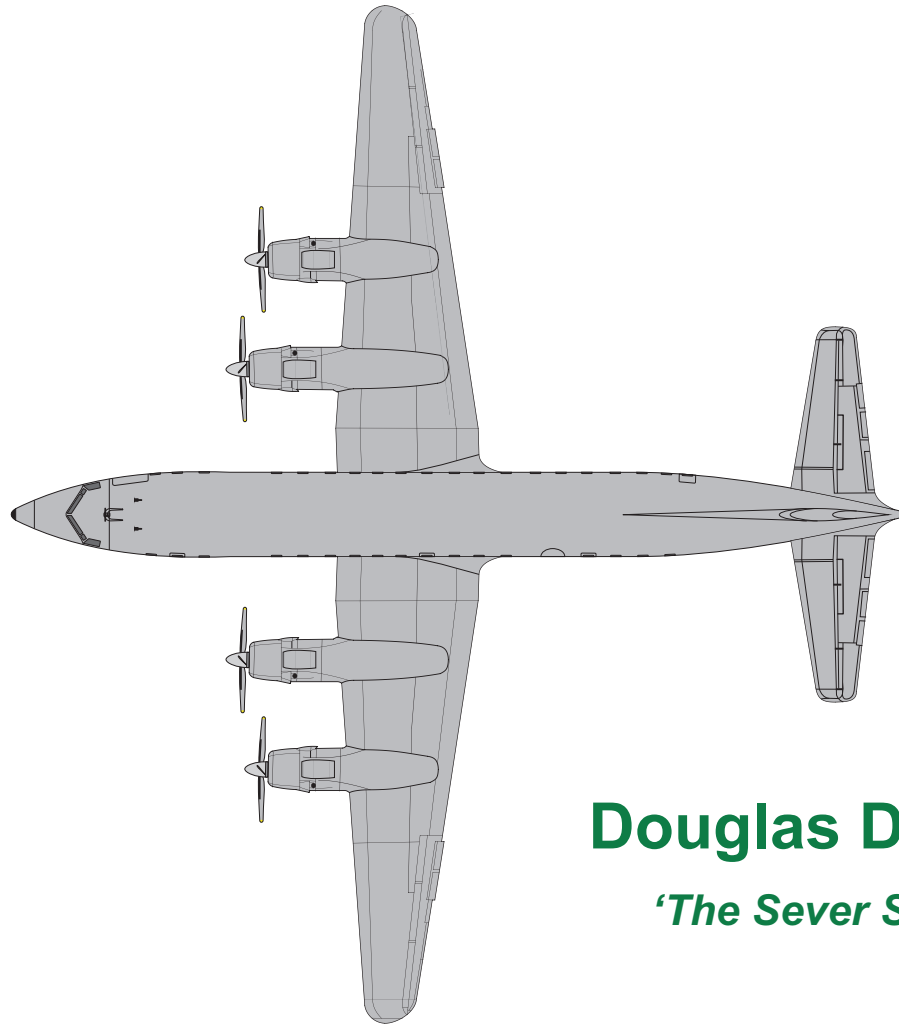
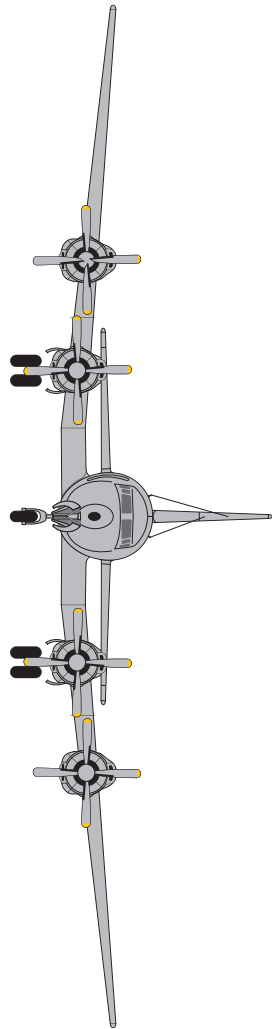
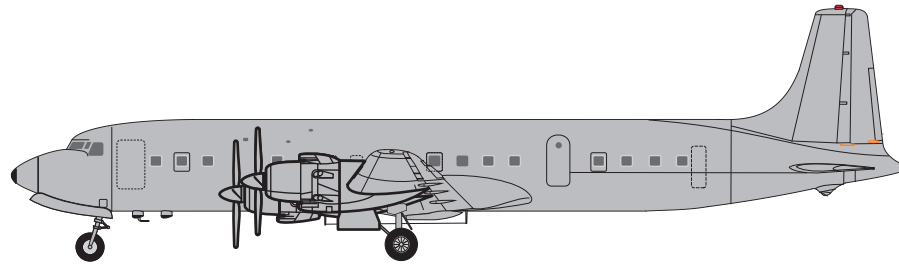

Douglas DC-7C

'The Sever Seas'

3 ASSEMBLE THE ENGINES

A Paint the engine details on the front of each engine core as shown in Figure 3.

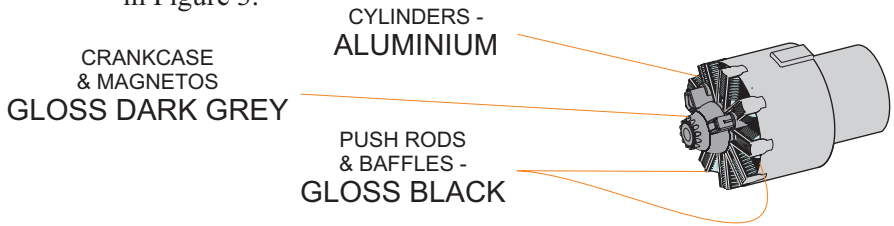

Figure 3

B Assembles the engine as shown in Figure 4.

- 1 Decide if the gills are to be shown open or closed and use the appropriate part.
- 2 The engine core is used to assemble the other three parts.
- 3 The propeller is not attached at this time.
- 4 Do steps 3 A thru 3 B 2 again for the other three engines.

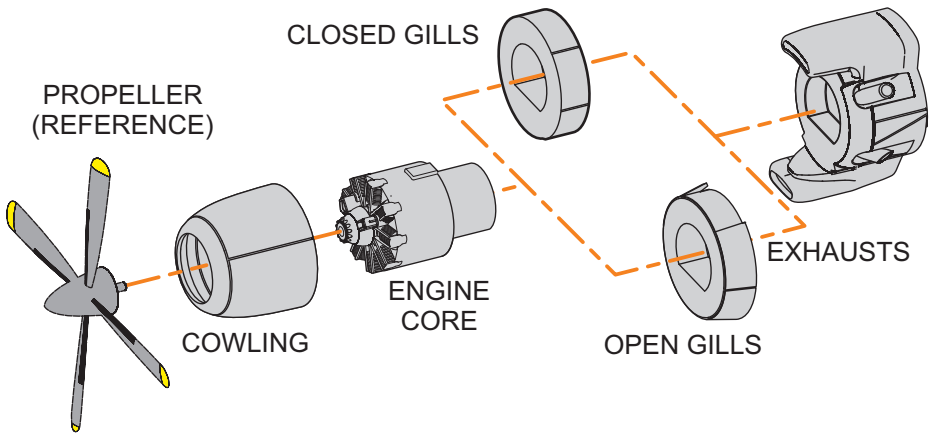

Figure 4

4 Assemble the fuselage as shown in Figure 5.

- A Fit the window glazing strips in each section of fuselage,
- B Cut window apertures in the fuselage plugs (if appropriate).
- C Build the fuselage in accordance with the kit instructions for the flight deck and nose landing gear bay.
- D Assemble the fuselage sections and the fuselage plugs, making sure that the fuselage parts are correctly aligned.
- E Add any glazing which is necessary.

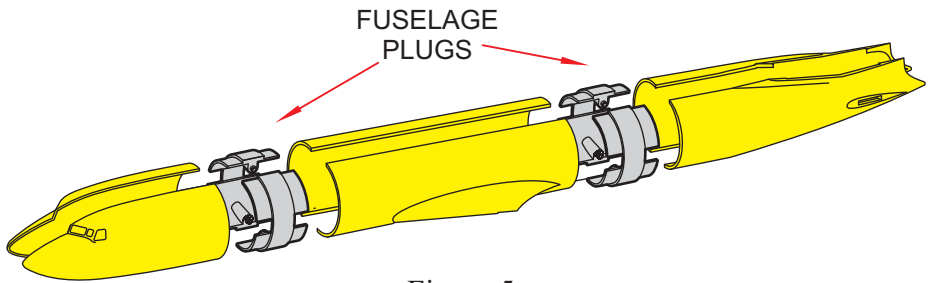

Figure 5

- 5 Attach the wings, engines and saddle tanks as shown in Figure 6.
 - A Attach the centre section to the fuselage. Make sure it is correctly aligned before the adhesive cures.
 - B Attach the outer wings which were prepared in step 2 B 2 to the centre section.
 - C Clip No.1 engine assembly to the front of the nacelle firewall - do not attach it at this time. Align the engine and the No.1 saddle tank and attach the saddle tank to the wing. Do this procedure again for the other three engines and saddle tanks. Allow the adhesive to cure, then remove the four engine assemblies.
 - D Attach the engines permanently and allow the adhesive to cure..

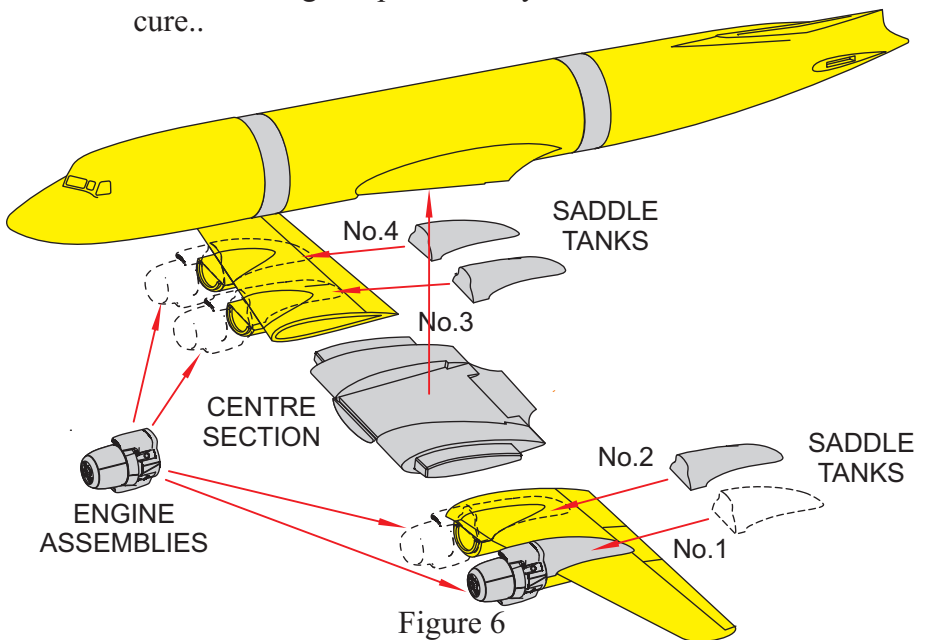

Figure 6

- 6 Attach the horizontal stabilizers.
 - A Assemble the horizontal stabilizers.
 - B Attach the horizontal stabilizers to the rear fuselage and make sure that they are horizontal while the adhesive cures.
- 7 Final assembly
 - A Fill and sand all joints in the airframe as necessary.
 - B Attach the landing gear as shown in the kit instructions.
 - C Paint the propellers with yellow blade tips and black deicer boots.
 - D Mask all transparencies, then paint the model as required.
 - E Remove all the masking.
 - F Attach the propellers.

© Aircraft In Miniature Ltd 2019

The manufacturers reserve the right to alter parts; add to, or delete parts without prior notification in the interests of quality control, production, or product improvement.

Errors And Omissions Excepted.

This kit is manufactured in the United Kingdom by

Aircraft In Miniature Limited

19, Watling Street, Nuneaton, Warwickshire, CV11 6JJ, England

Email: info@aim72.co.uk - Web site: www.aim72.co.uk