

# 1:72 RAF MD300 TRACTOR

2011 © Aircraft In Miniature Limited

These are a larger version of the instructions printed inside the header of each kit, plus some more detailed written instructions (shown in blue).

- 1 Remove all burrs from cast metal and brass parts.
- 2 Remove the feed from the bottom of the cast resin body (we suggest that you rub it down on coarse wet and dry paper, used wet and while wearing a mask - resin dust is injurious).
- 3 Fold the ends of the cab roof down. Grip the ends very firmly adjacent to the fold line, then fold each end to the required angle. There are two folds in the front panel (See sketch A).  
Note - there are fold lines etched on the inside of each fold.
- 4 Attach the side panels to the roof (See sketch A).
- 5 Attach the steering wheel to the etched steering column (See sketch A).
- 6 Fold the square mounting plate on each of the two handed rear view mirrors at right angles to the mirror arm (See sketch A).

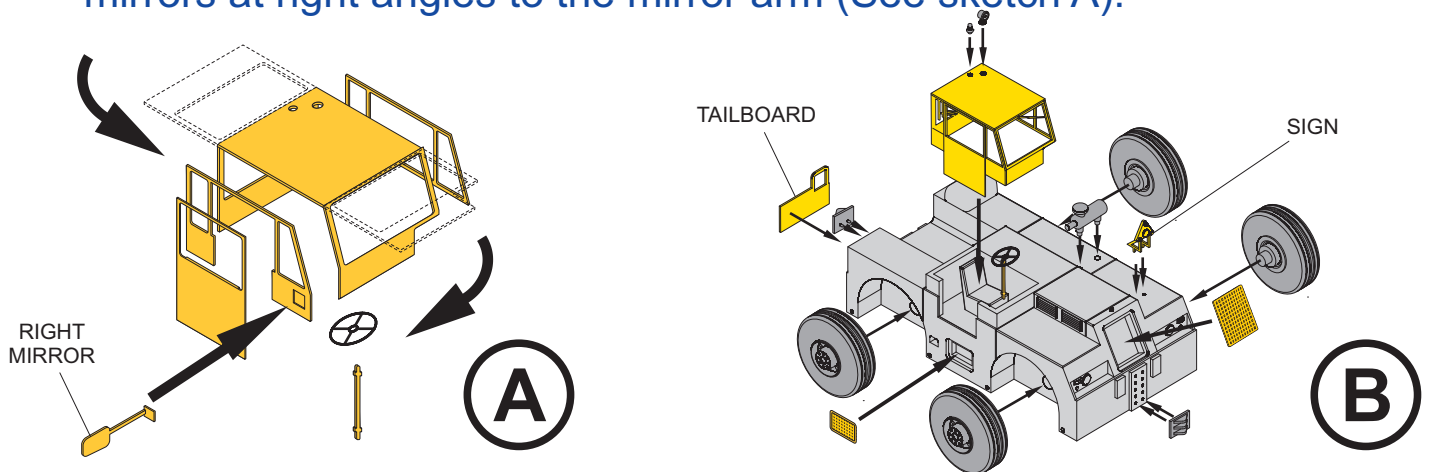

- 7 Attach the four wheels to the body (See sketch B).
- 8 Attach the steering column (with steering wheel attached) to the body (See sketch B).
- 9 Paint the cab interior details.
- 10 Attach the assembled cab to the body, then attach the cab door (See sketch B).
- 11 Attach the detail parts to the body (See sketch B). These are the:
  - Brass radiator and side cooling grills to the body
  - Cast metal front and rear hitches to the body
  - Cast metal beacon and spotlight to the cab roof
  - Fold the supports then attach brass the sign to the left front wing
  - Cast metal air cleaner to the left body
  - Brass tailboard to the rear of the body.
- 12 Check [www.aim72.co.uk](http://www.aim72.co.uk) for self-print decals to down load.
- 13 Paint the model.